

VERTICALES

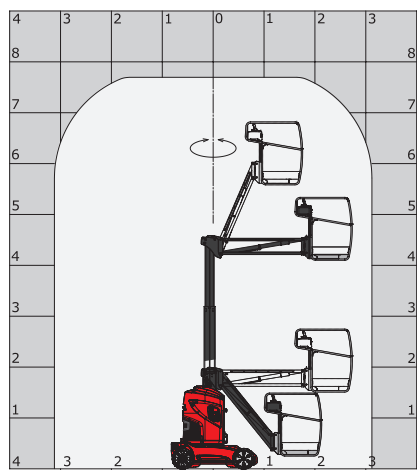

80 VJR

Capacité du panier	kg	200
Hauteur de travail	m	7.65
Hauteur de plateforme	m	5.65
Déport de travail	m	3.24
Surplomb	m	4.24
Dimensions nacelle (L x l x h)	m	2.95 x 0.99 x 1.99
Dimensions transport (L x l x h)	m	2.95 x 0.99 x 1.99
Dimensions panier (L x l)	m	1.11 x 0.93
Batterie	Ah/V	250 / 24
Pneumatiques		Bandages non marquant
Poids (à vide)	kg	2250



100 VJR

kg	200
m	9.85
m	7.85
m	3.15
m	6.67
m	2.8 x 0.99 x 1.99
m	2.8 x 0.99 x 1.99
m	1.11 x 0.93
kw	250 / 24
	Bandages non marquant
kg	2650

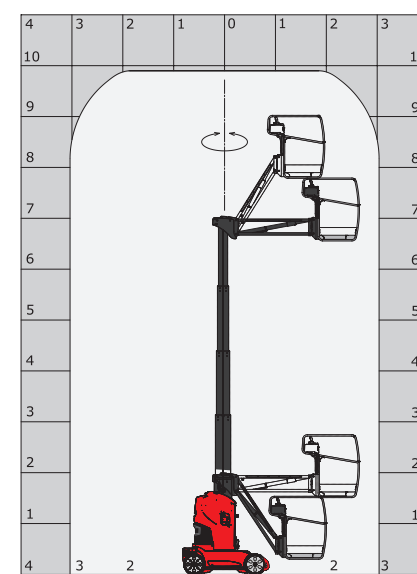

Nombre de personnes



Rotation tourelle



Rotation tourelle continue



Roues directrices & roues motrices



Pente franchissable



90 V' AIR



kg	230
m	9
m	7
m	2.04
m	-
m	2.31 x 1.1 x 2.31
m	2.31 x 1.1 x 2.31
m	0.95 x 0.68
Ah/V	250 / 24
	Bandages non marquant
kg	2710

